



特點 CHARACTERISTICS :

最高使用壓力320 kgf/cm²

用於底板安裝

用於油路塊安裝

借助於安裝在其上的方向電磁閥操作卸荷

Max.operated pressure 320 kgf/cm²

For subplate mounting

For installation in manifolds

Solenoid operated unloading via a built-in directional spool valve, or directional poppet valve

4WE-06電磁閥重量 SOLENOID WEIGHT (kg)		
	AC	DC
帶1個電磁鐵 Single coil	1.6	1.7
帶2個電磁鐵 Two coils	2.1	2.1

型式 MODEL	O型環油口A,B O RING A,B PORT	O型環油口X O RING X PORT	附屬安裝螺絲 SOCHOL CAP SCREW	底板型式 SUBPLATE TYPE
DB,DBW-G03	P18 NBR90 9B	P9 NBR90 9B	M12 x 40L....4PCS	MA-02-1
DB,DBW-G06	P28 NBR90 9B	P9 NBR90 9B	M16 x 50L....4PCS	MA-02-2
DB,DBW-G10	P34 NBR90 9B	P9 NBR90 9B	M20 x 55L....4PCS	MA-02-3

閥類型符號 SYMBOL

DB-**** 	DB-****X 	DB-****Y 	DB-****XY
DBW-**** 常開 NORMALLY OPEN 	DBW-****X 常開 NORMALLY OPEN 	DBW-****Y 常開 NORMALLY OPEN 	DBW-****XY 常開 NORMALLY OPEN
常閉 NORMALLY CLOSED 	常閉 NORMALLY CLOSED 	常閉 NORMALLY CLOSED 	常閉 NORMALLY CLOSED

規格說明 SPECIFICATION :

型式 MODEL		最高設定壓力 MAX. PRESSURE kgf/cm ²	壓力調整範圍 PRESSURE ADJ. RANGE kgf/cm ²	最大流量 MAX. FLOW l/min	Y口容許背壓 MAX. BACK kgf/cm ²	重量 (不含電磁閥) WEIGHT(NO CONTAIN SOLENOID VALVE) (kg)	
DB-G03	DBW-G03	320	1 : 7-70	100	160	3.5	3.4
DB-G06	DBW-G06		2 : 7-140	200	160	4.5	4.4
DB-G10	DBW-G10		3 : 7-320	400	160	6.0	5.9

型號說明 HOW TO ORDER :

DB W - G 06 - A - 1 - XY - D - W220 - 20

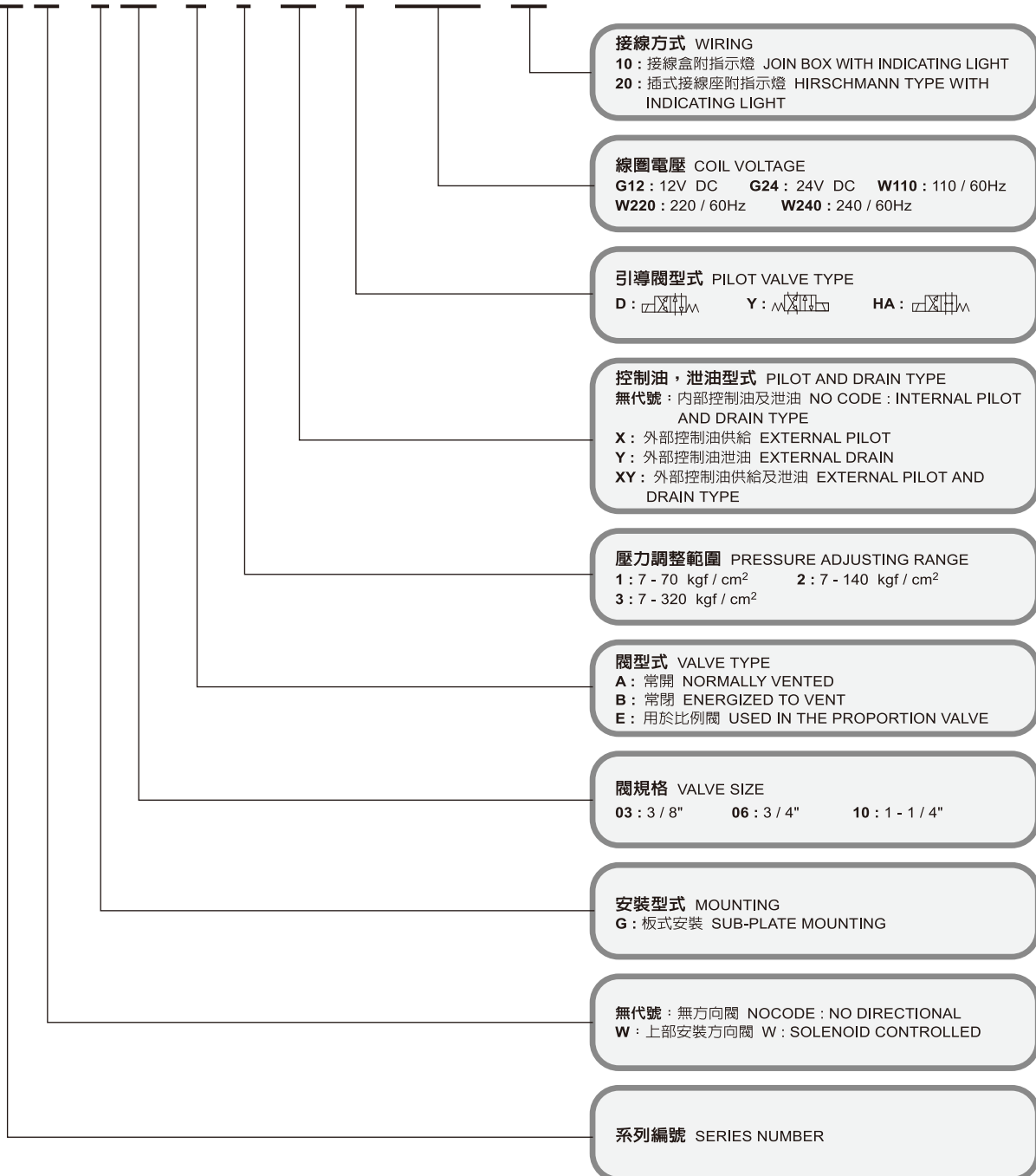

功能說明 FUNCTIONAL DESCRIPTION :

DB/DBW 型壓力控制閥是先導式溢流閥。

它們用於限制(DB)或用電磁閥(DBW)限制及卸荷系統壓力，該溢流閥(DB)的組成主要包括帶主閥蕊插件(3)的主閥(1)和帶壓力調節元件的先導閥(2)。

DB型溢流閥

油路A中的壓力作用於主閥蕊(3)上。同時，壓力經帶節流孔(4)和(5)的控制通路(6)和(7)作用在主閥蕊(3)的彈簧加載側及先導閥(2)的球(8)上，如果通路A的壓力超過彈簧(9)的設定值球(8)克服彈簧(9)開啓。

對此該信號由控制線(10)和(6)從A通路內部供給。主閥蕊(3)彈簧加載側的油液經過控制通路(7)節流(11)和球閥(8)流入彈簧腔(12)，從這裡內部供給-DB...型由控制通路(13)或外部供給-DB...-5X...Y-型，由控制通路(14)引入油箱，節流孔(4)和(5)在主閥蕊(3)產生壓降由A管至B管連接口打開，油液由A管流向B管而設定工作壓力保持不變。溢流閥借助油口X(15)可對不同壓力(第二個壓力額定值)卸荷或切換。

General

DB, DBW Pressure valves are pilot operated pressure relief valves.

They are used for the limitation (DB) or limitation and solenoid actuated unloading (DBW) of the operating pressure. The pressure relief valves (DB) consist mainly of the main valve (1) with main spool assembly (3) and pilot valve (2) with pressure adjustment element.

Pressure relief valve type DB

The pressure present in port A acts on the main spool (3). At the same time pressure is present via the control lines (6) and (7), which are fitted with orifices (4) and (5) on the spring loaded side of the main spool (3) and at the ball (8) in the pilot valve (2). If the pressure in port A exceeds the valve set at the spring (9) the ball (8) opens against the spring (9).

The signal for this comes internally via the control lines (10) and (6) from port A. The pressure fluid on the spring loaded side of the main poppet (3) now flows via the control line (7), orifice bore (11) and ball (8) into the spring chamber (12). In type DB...-5X/... it flows internally via the control line (13) to tank, or, in type DB...5X/...Y.. externally via the control line (14). Due to the orifices (4) and (5) a pressure drop occurs at the main spool (3), the connection from port A to port B is open. Now the pressure fluid flows from port A to port B whilst maintaining the set operating pressure.

The pressure relief valve may be unloaded or switched over to a different pressure (second pressure stage) via port "X" (15).

剖面圖 SECTION :

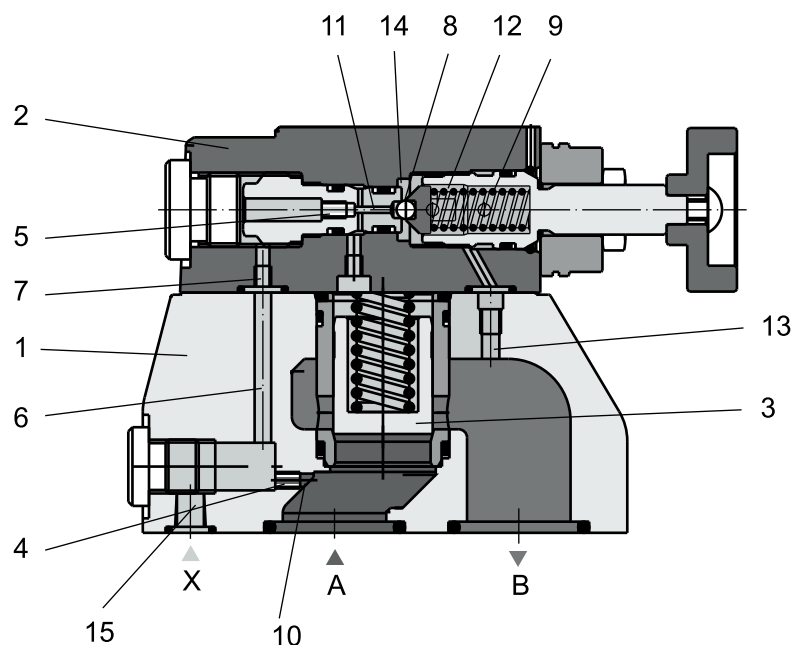

單位UNIT : mm

安裝尺寸 INSTALLATION DIMENSIONS

DB-G03

通用底板尺寸
 APPLICATIVE
 SUB-PLATE DIMENSIONS
MA - 02 - 1
 (詳見 F-f1-02 Page F-f1-02)

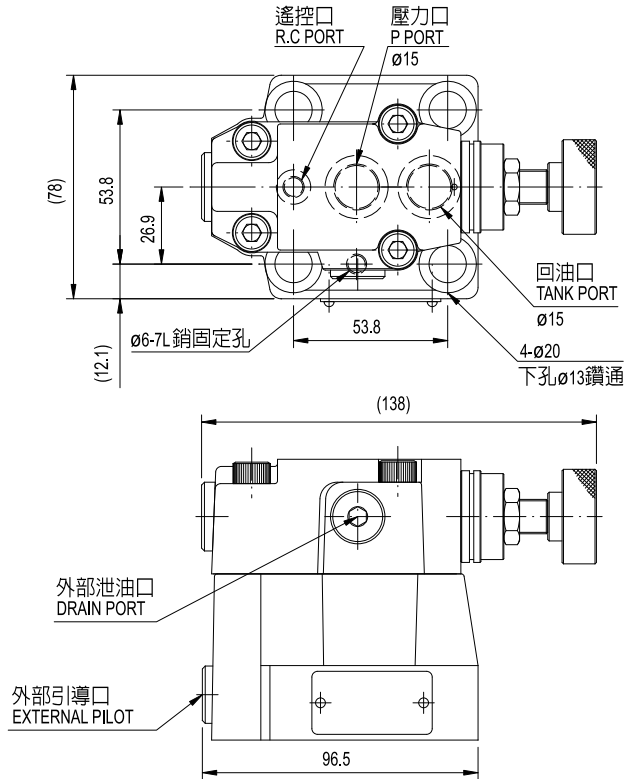

DB-G06

通用底板尺寸
 APPLICATIVE
 SUB-PLATE DIMENSIONS
MA - 02 - 2
 (詳見 F-f1-02 Page F-f1-02)

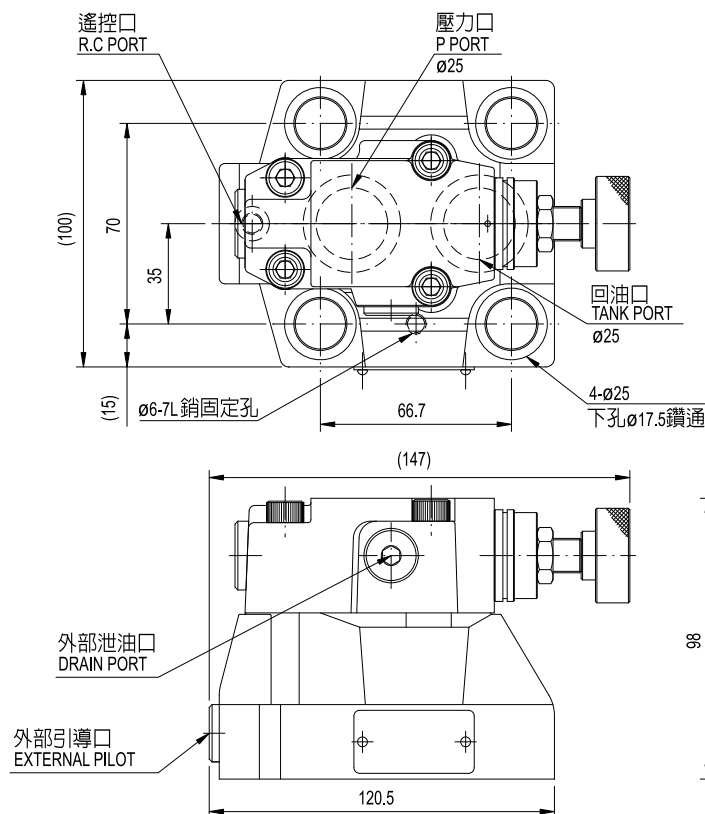

單位UNIT : mm

安裝尺寸 INSTALLATION DIMENSIONS

DB-G10

通用底板尺寸
 APPLICATIVE
 SUB-PLATE DIMENSIONS
MA - 02 - 3
 (詳見 F-f1-02 Page F-f1-02)

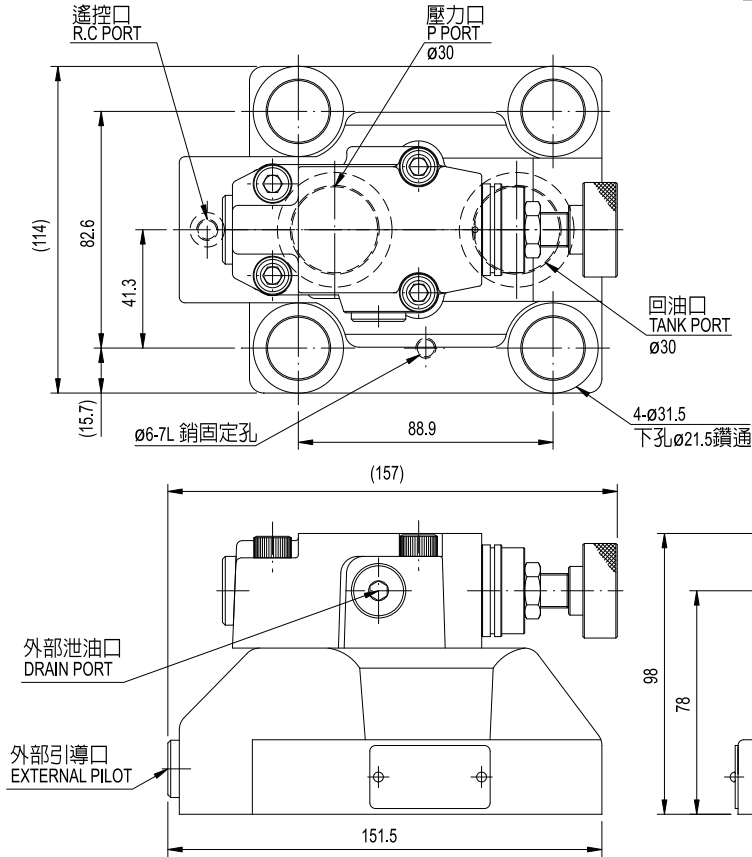

單位UNIT : mm

安裝尺寸 INSTALLATION DIMENSIONS

DBW-G03-E-※

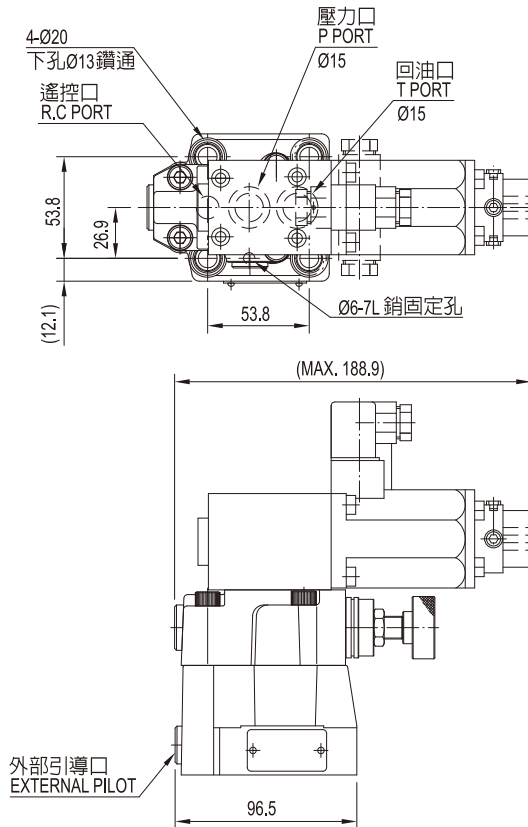

通用底板尺寸
 APPLICATIVE
 SUB-PLATE DIMENSIONS
MA - 02 - 1
 (詳見 F-f1-02 Page F-f1-02)

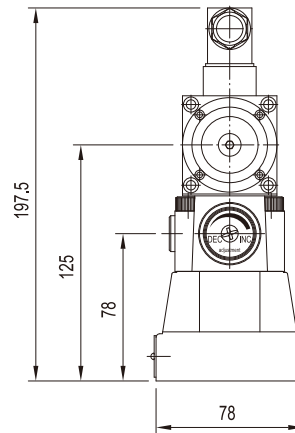

DBW-G06-E-※

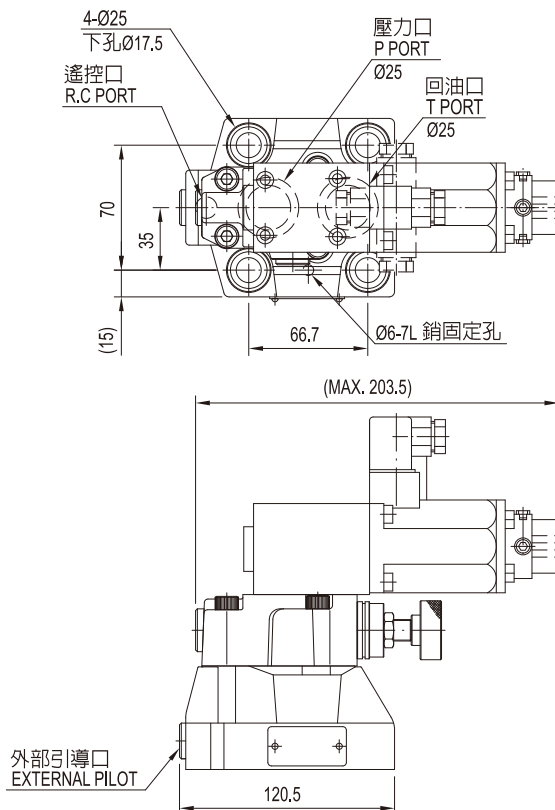

通用底板尺寸
 APPLICATIVE
 SUB-PLATE DIMENSIONS
MA - 02 - 2
 (詳見 F-f1-02 Page F-f1-02)

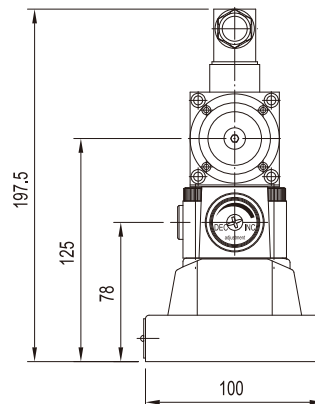

單位UNIT : mm

安裝尺寸 INSTALLATION DIMENSIONS

DBW-G10-E-※

通用底板尺寸
 APPLICATIVE
 SUB-PLATE DIMENSIONS
MA - 02 - 3
 (詳見 F-f1-02 Page F-f1-02)

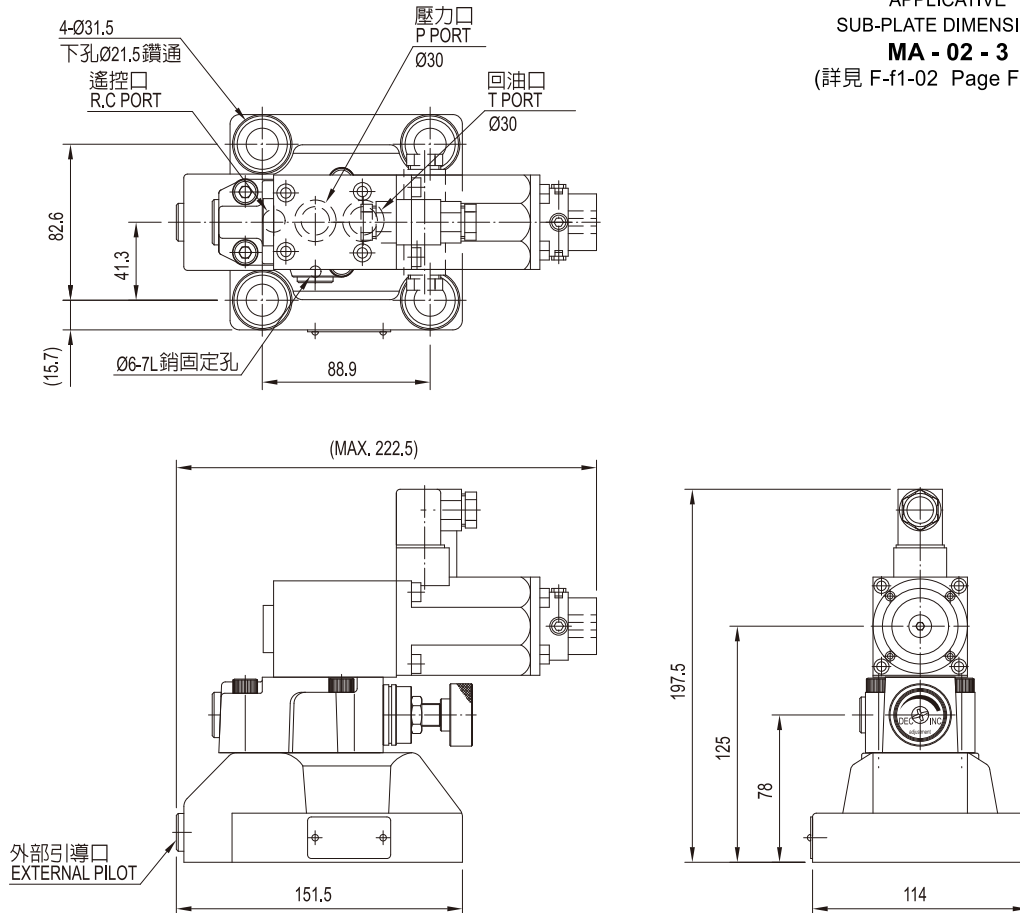

測試條件 PERFORMANCE CURVES:

測試油黏度 TEST FLUID VISCOSITY : 35 cSt

測試油溫度 TEST TEMPERATURE : 50°C

流量—壓力特性 NOMINAL OVERRIDE

● DB/DBW-G03

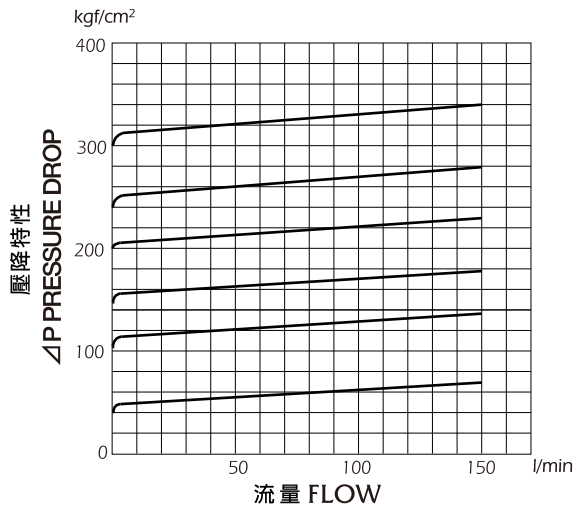

最低調整壓力特性 Min. Adj. PRESSURE

● DB/DBW-G03

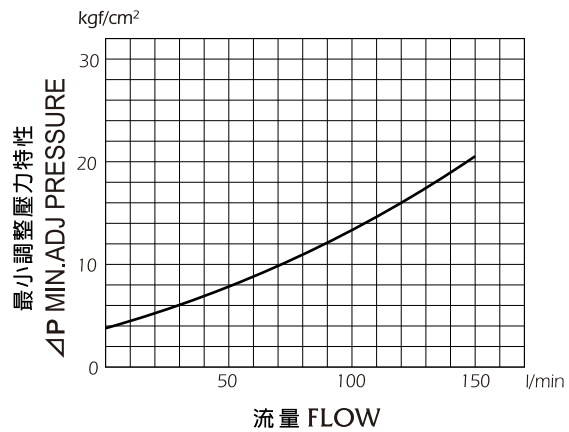

● DB/DBW-G06

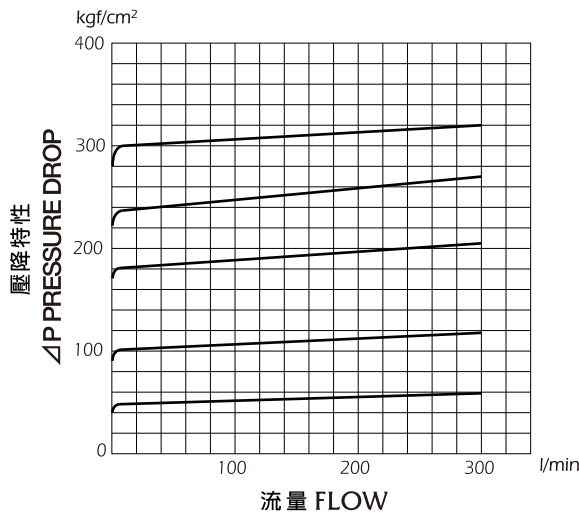

● DB/DBW-G06

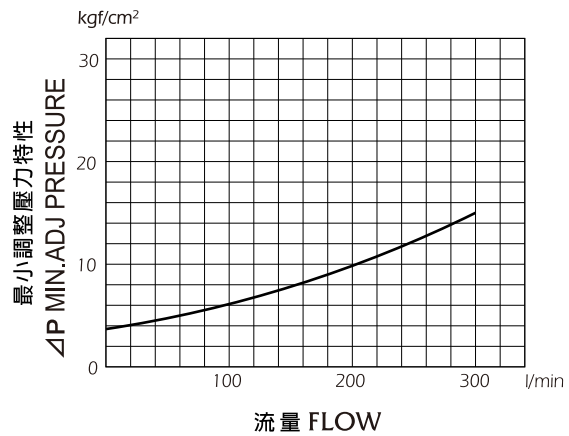

● DB/DBW-G10

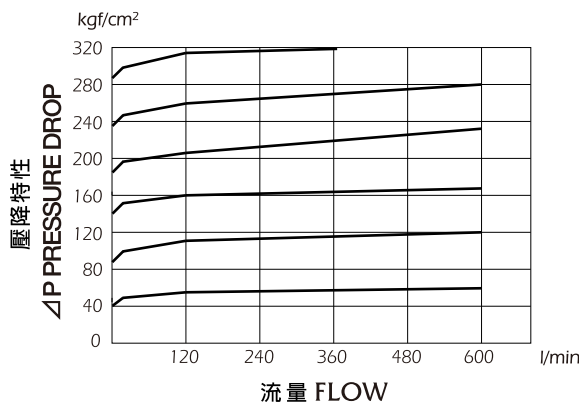

● DB/DBW-G10

