

閥類型符號 SYMBOL

BSG-※

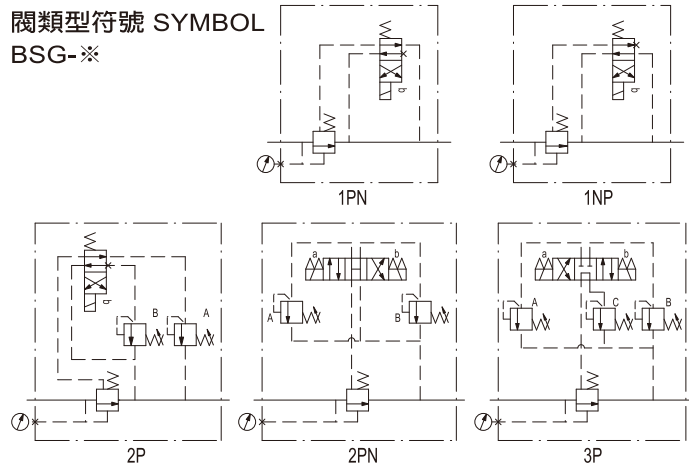

規格說明 SPECIFICATION :

型式 MODEL	最高使用壓力 MAX. OPERATING PRESSURE (kgf/cm ²)	壓力調整範圍 PRESSURE ADJ. RANGE kgf/cm ²	最大流量 MAX. FLOW l/min	重量(不含電磁閥) (kg) WEIGHT(NO CONTAIN SOLENOID VALVE)				
				MODEL	1PN	2PN	2P	3P
BSG-03-※	250	0 : 7-35	100	BSG-03	6.0	8.0	8.0	8.2
BSG-06-※ BST-06-※		1 : 7-70	200	BSG-06	9.4	9.2	9.2	9.4
		2 : 7-140	400	BST-06	4.9	6.7	6.7	6.8
BSG-10-※ BST-10-※		3 : 7-210	400	BSG-10	11.5	14	14.1	14.3
				BST-10	7.9			

型號說明 HOW TO ORDER :

BS G - 03 - 1PN - 3 - 30 - D - W220 - 20 - A

彈簧編號 SPRING SERIAL NUMBER

導閥設計編號 VALVES DESIGN NUMBER
 10 : 帶燈的集中連接盒(with lamp central connection)
 20 : 插入式接頭帶密封套(plug-in connection)

線圈電壓 COIL VOLTAGE
 G12 : 12V DC G24 : 24V DC
 W110 : 110 / 60Hz W220 : 220 / 60Hz W240 : 240 / 60Hz

引導閥型式 PILOT VALVE TYPE
 D : Y : G :
 H : HA :

設計編號 DESIGN NUMBER
 30 : 標準型 STANDARD TYPE
 32 : T型推環直結式 THRUST RING LINK TYPE

壓力調整範圍 PRESSURE ADJUSTING RANGE
 0 : 7 - 35 kgf / cm² 1 : 7 - 70 kgf / cm²
 2 : 7 - 140 kgf / cm² 3 : 7 - 210 kgf / cm²

閥型式 VALVE TYPE
 1PN : 常開式 NORMALLY VENTED
 1NP : 常閉式 ENERGIZED TO VENT
 2P : 兩段調整壓力 DUAL PRESSURE ADJUSTING RANGES
 2PN : 兩段調整壓力加常開式 DUAL PRESSURE AND VENT
 3P : 三段調整壓力 THREE PRESSURE ADJUSTING RANGES

閥規格 VALVE SIZE
 03 : 3 / 8" 06 : 3 / 4" 10 : 1 - 1 / 4"

安裝型式 MOUNTING
 G : 板式安裝 SUB-PLATE MOUNTING
 T : 管式安裝 THREADED CONNECTIONS

系列編號 SERIES NUMBER

附屬品 ATTACHMENT :

型式 MODEL	安裝螺絲 SOL HOLE CAP SCREW	
BSG-03	M12 X 75L.....2pcs	M12 X 95L.....2pcs
BSG-06	M16 X 60L.....2pcs	M16 X 80L.....2pcs
BSG-10	M20 X 75L.....2pcs	M20 X 95L.....2pcs

4WE-06電磁閥重量 SOLENOID WEIGHT (kg)		
	AC	DC
帶1個電磁鐵 Single coil	1.6	1.7
帶2個電磁鐵 Two coils	2.1	2.1

BST-06-1PN/1NP.....DC

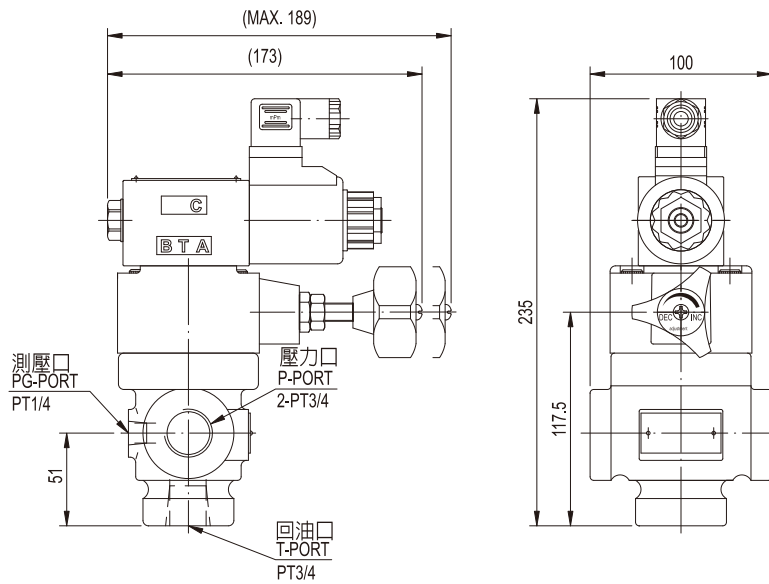

單位UNIT : mm

安裝尺寸 INSTALLATION DIMENSIONS

BST-06-2P....DC

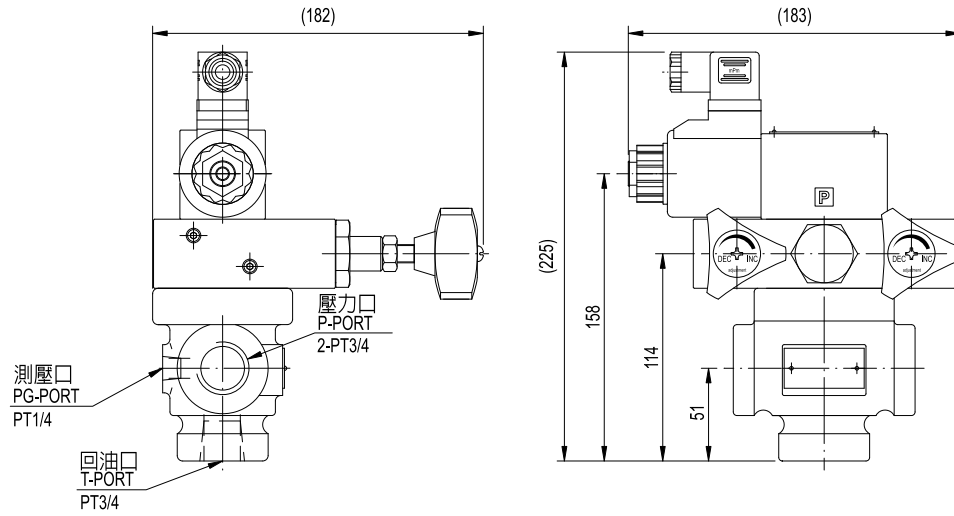

BST-06-2PN....DC

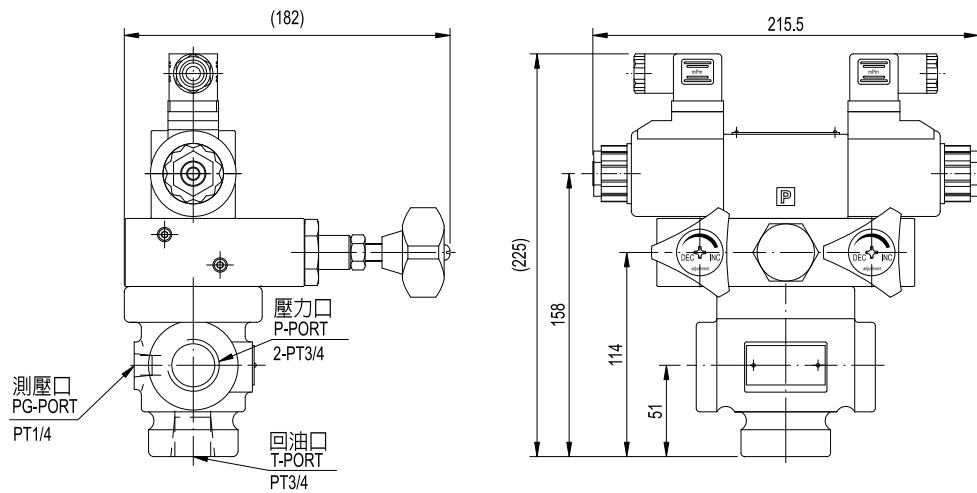

單位UNIT : mm

安裝尺寸 INSTALLATION DIMENSIONS

BST-06-3P....DC

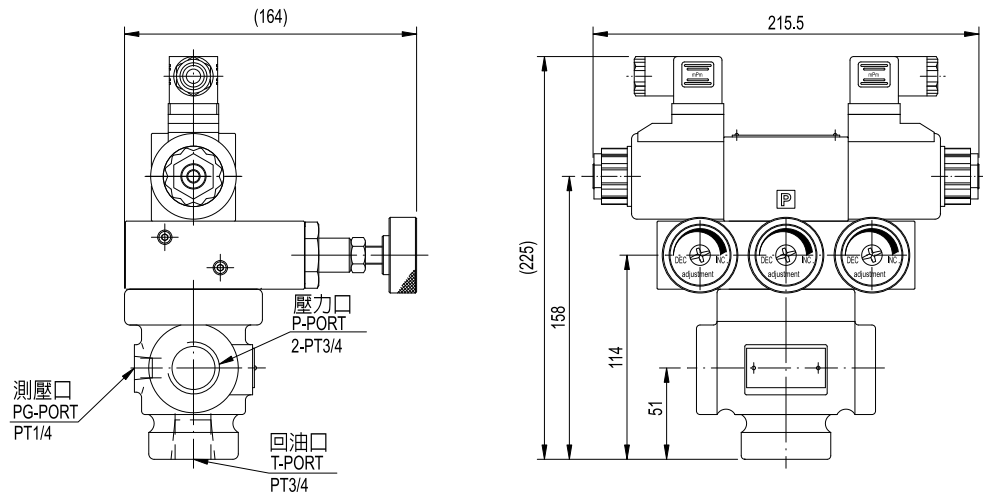

BST-10-1PN/1NP....DC

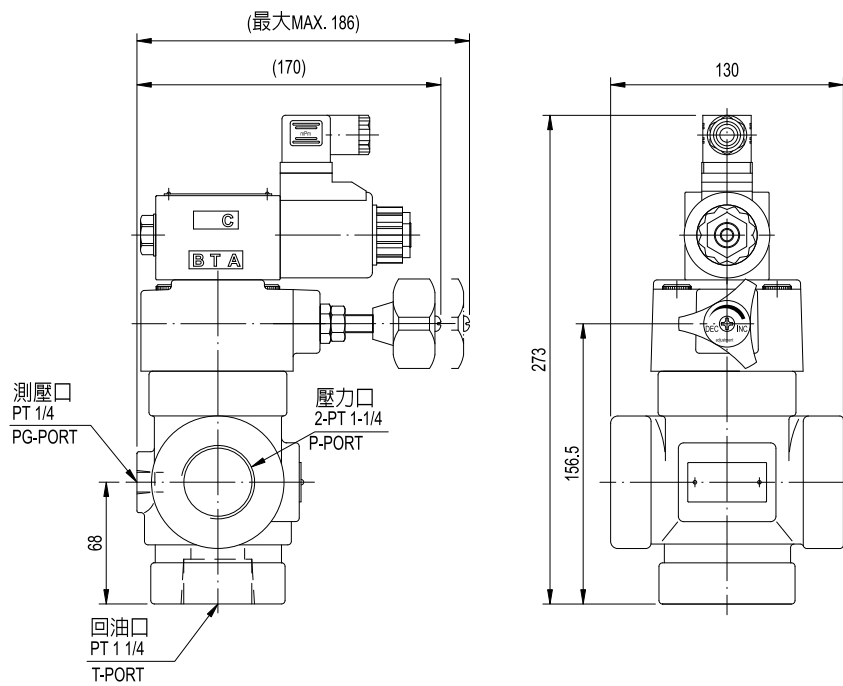

單位UNIT : mm

安裝尺寸 INSTALLATION DIMENSIONS

BSG-03-1PN/1NP...DC

通用底板尺寸
 APPLICATIVE
 SUB-PLATE DIMENSIONS
MA - 02 - 1
 (詳見 F-f1-02 Page F-f1-02)

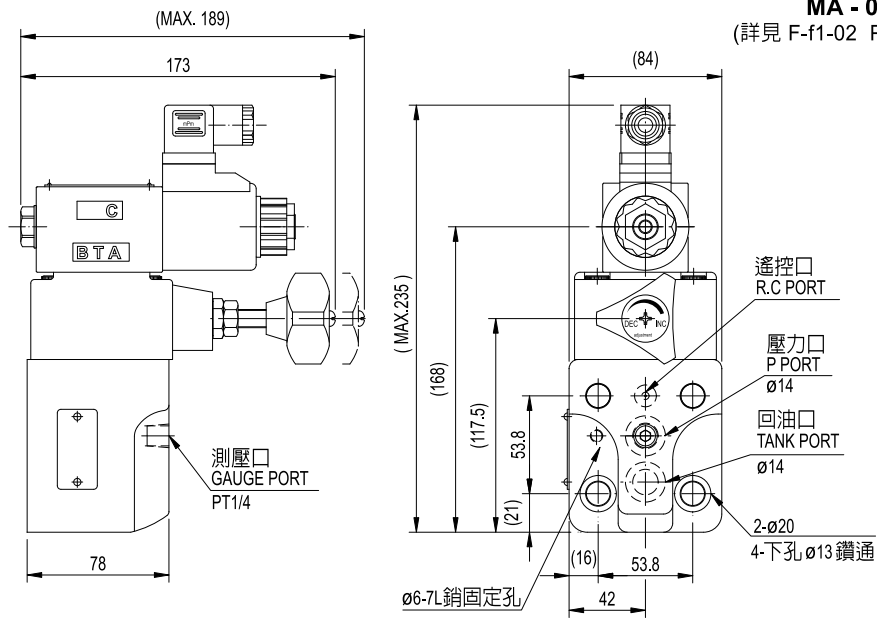

BSG-03-2P....DC

通用底板尺寸
 APPLICATIVE
 SUB-PLATE DIMENSIONS
MA - 02 - 1
 (詳見 F-f1-02 Page F-f1-02)

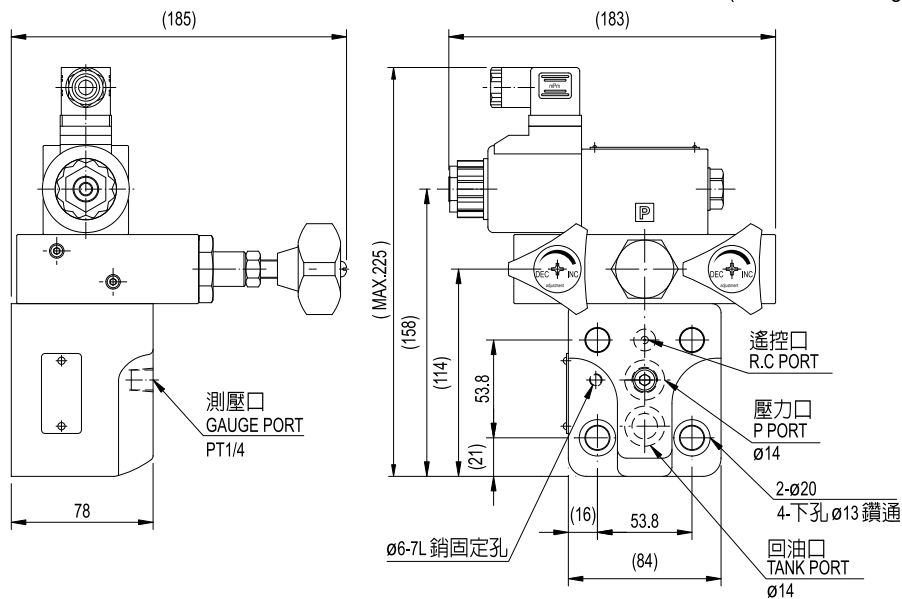

單位UNIT : mm

安裝尺寸 INSTALLATION DIMENSIONS

BSG-03-2PN....DC

通用底板尺寸
 APPLICATIVE
 SUB-PLATE DIMENSIONS
MA - 02 - 1
 (詳見 F-f1-02 Page F-f1-02)

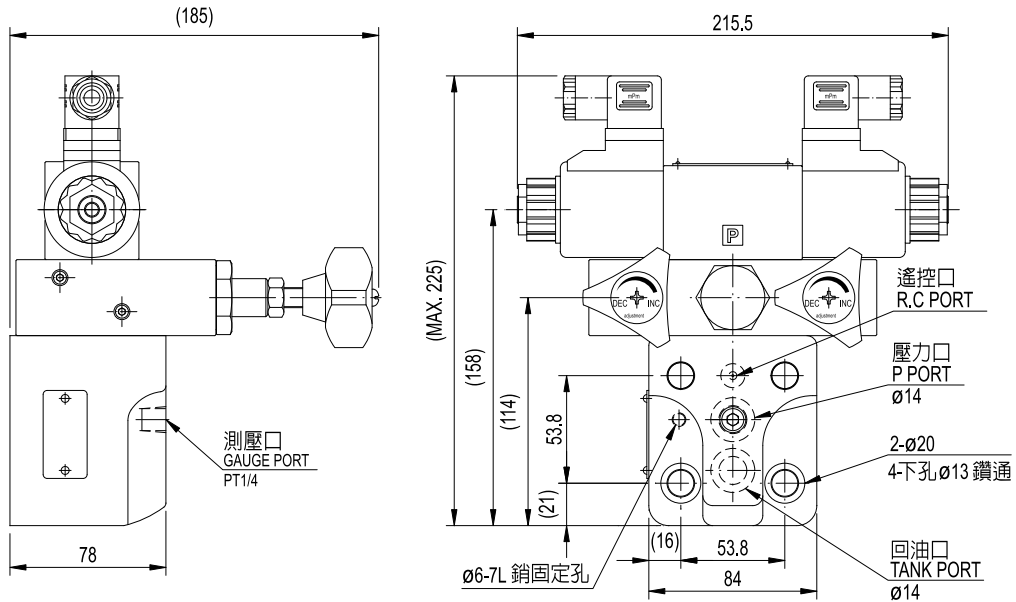

BSG-03-3P....DC

通用底板尺寸
 APPLICATIVE
 SUB-PLATE DIMENSIONS
MA - 02 - 1
 (詳見 F-f1-02 Page F-f1-02)

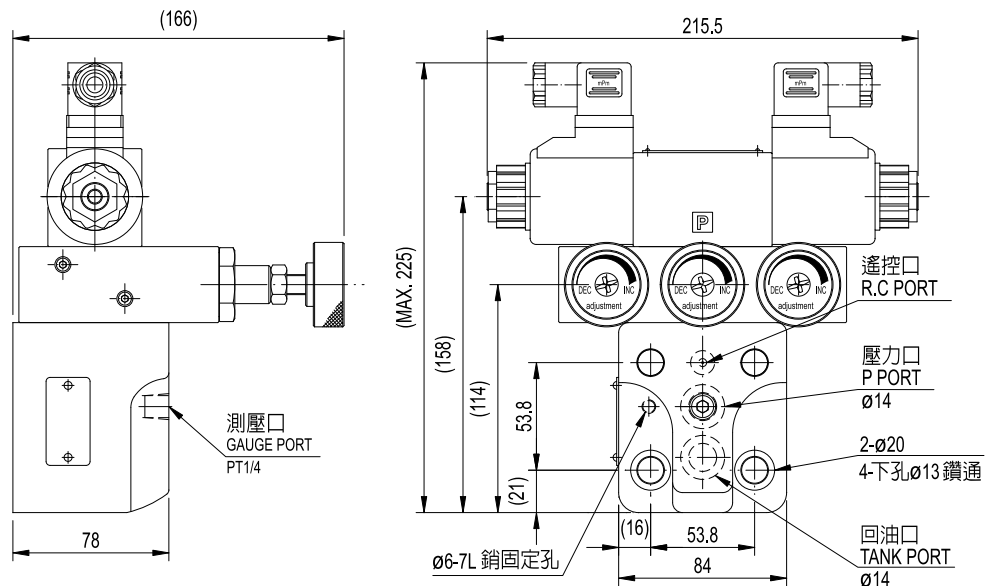

單位UNIT : mm

安裝尺寸 INSTALLATION DIMENSIONS

BSG-06-1PN/1NP...DC

通用底板尺寸
 APPLICATIVE
 SUB-PLATE DIMENSIONS
MA - 02 - 2
 (詳見 F-f1-02 Page F-f1-02)

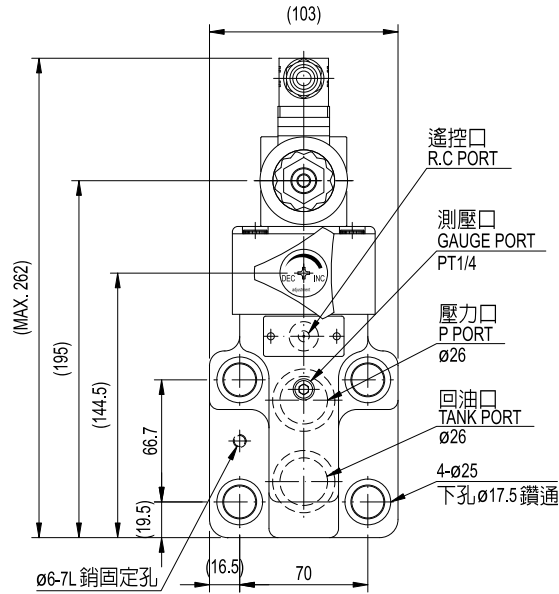
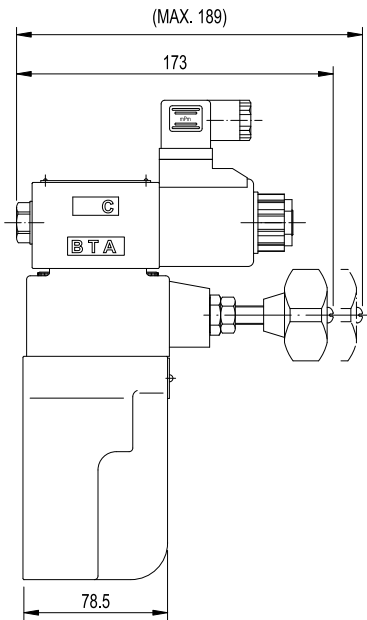

BSG-06-2P...DC

通用底板尺寸
 APPLICATIVE
 SUB-PLATE DIMENSIONS
MA - 02 - 2
 (詳見 F-f1-02 Page F-f1-02)

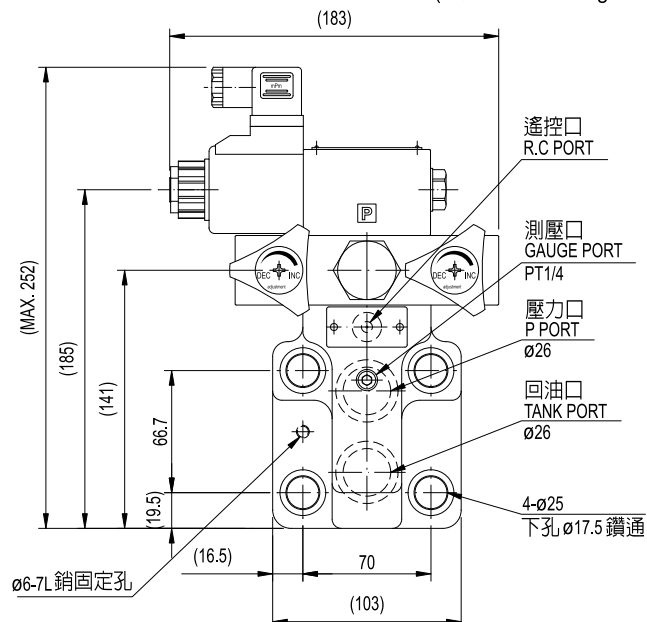
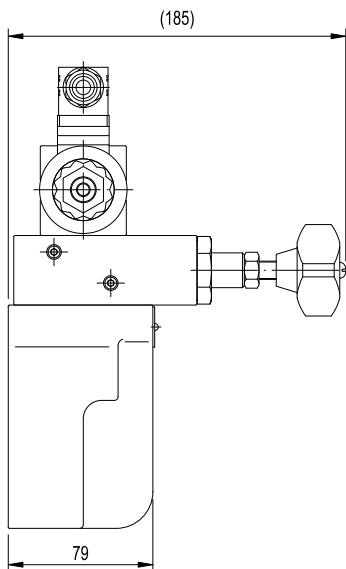

單位UNIT : mm

安裝尺寸 INSTALLATION DIMENSIONS

BSG-06-2PN....DC

通用底板尺寸
 APPLICATIVE
 SUB-PLATE DIMENSIONS
MA - 02 - 2
 (詳見 F-f1-02 Page F-f1-02)

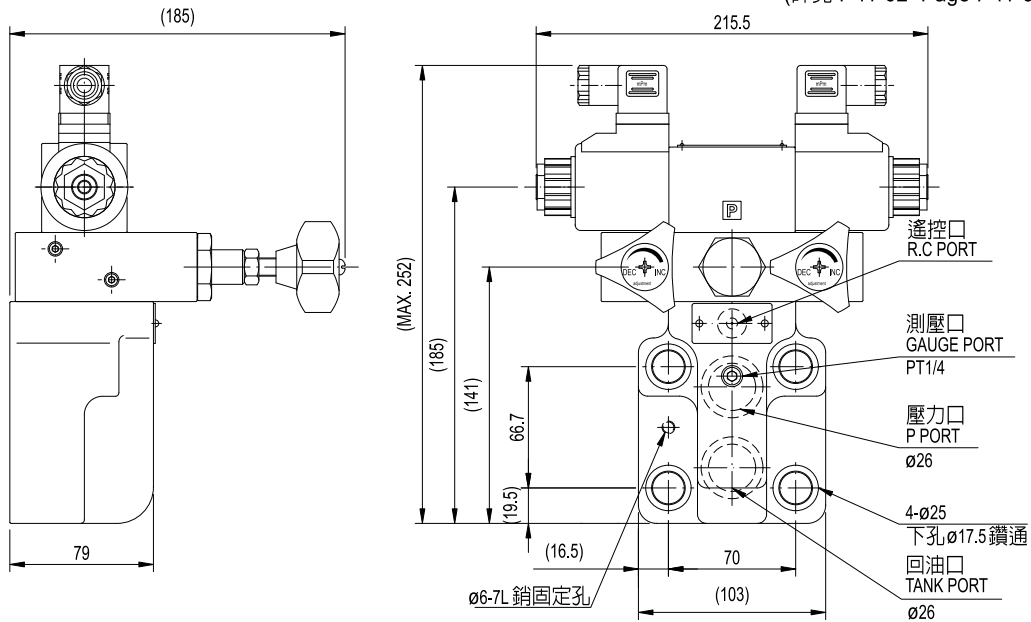

BSG-06-3P....DC

通用底板尺寸
 APPLICATIVE
 SUB-PLATE DIMENSIONS
MA - 02 - 2
 (詳見 F-f1-02 Page F-f1-02)

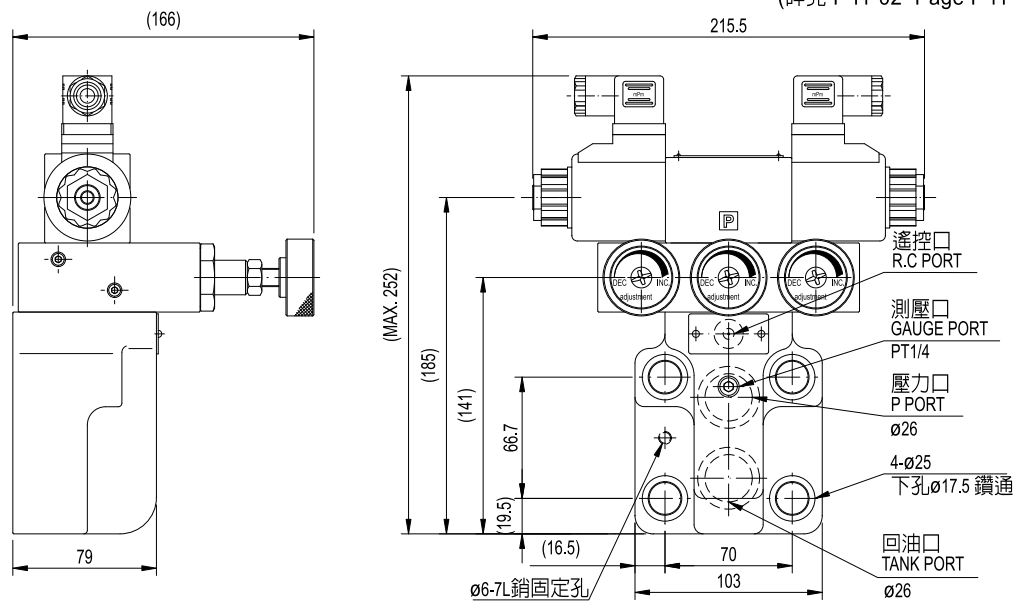

單位UNIT : mm

安裝尺寸 INSTALLATION DIMENSIONS

BSG-10-1PN/1NP...DC

通用底板尺寸
 APPLICATIVE
 SUB-PLATE DIMENSIONS
MA - 02 - 3
 (詳見 F-f1-02 Page F-f1-02)

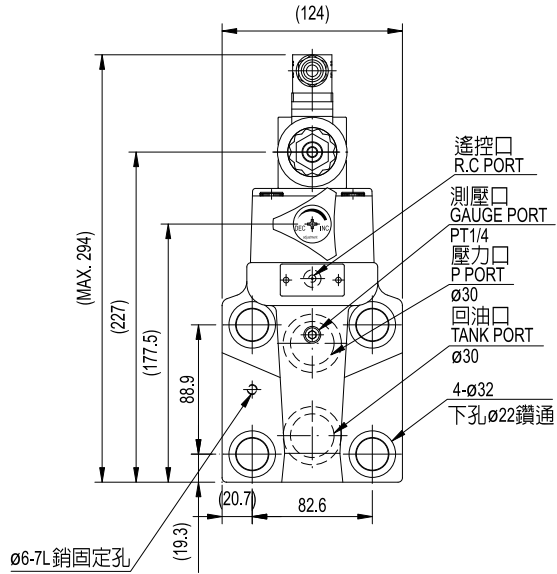
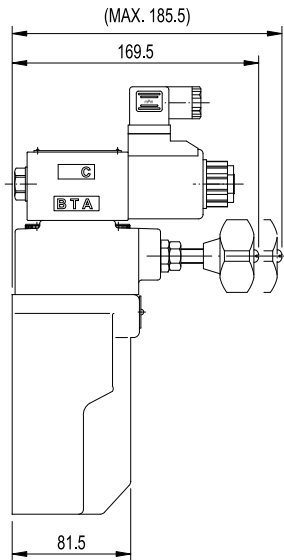

BSG-10-2P....DC

通用底板尺寸
 APPLICATIVE
 SUB-PLATE DIMENSIONS
MA - 02 - 3
 (詳見 F-f1-02 Page F-f1-02)

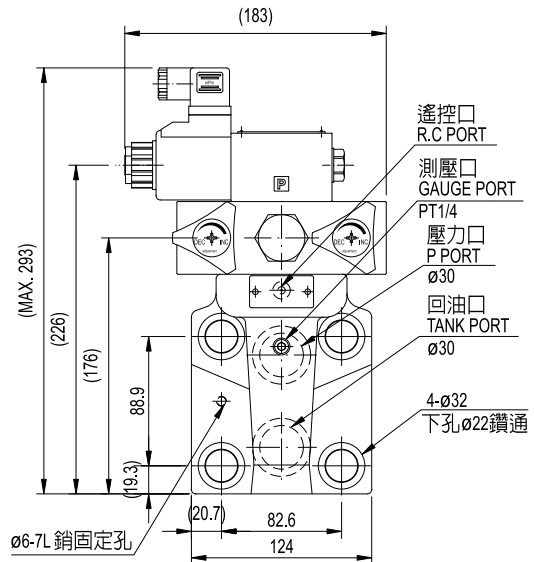
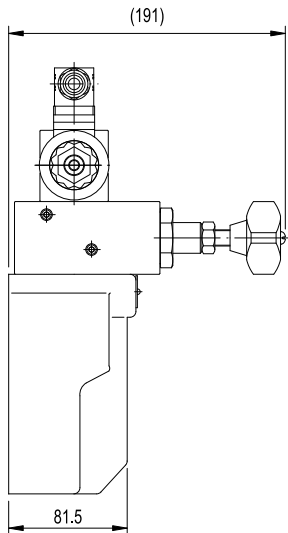

單位UNIT : mm

安裝尺寸 INSTALLATION DIMENSIONS

BSG-10-2PN....DC

通用底板尺寸

APPLICATIVE
SUB-PLATE DIMENSIONS

MA - 02 - 3

(詳見 F-f1-02 Page F-f1-02)

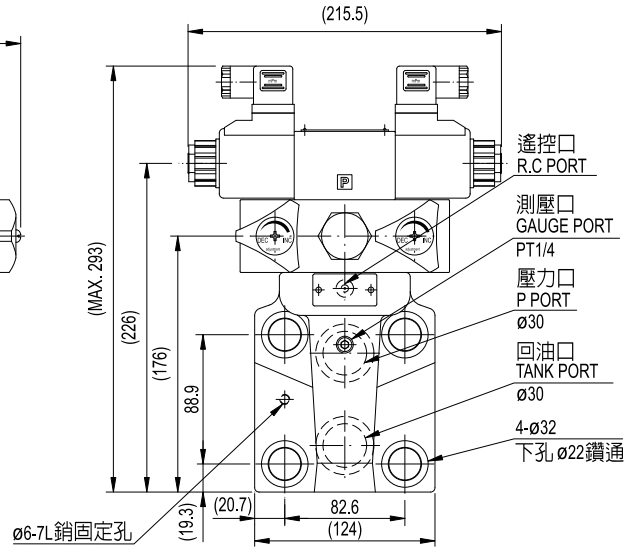
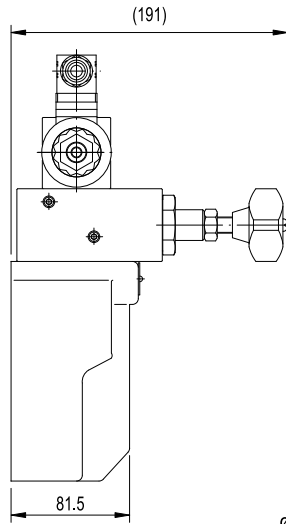

BSG-10-3P....DC

通用底板尺寸

APPLICATIVE
SUB-PLATE DIMENSIONS

MA - 02 - 3

(詳見 F-f1-02 Page F-f1-02)

